

AC Square Motors

Catalogue-2017/10 EU

For inverter vector controls

AMS

Series 71 - 132

0,37-28 kW

0,5-38 HP

2-178 Nm

(at 1500rpm)



Table of contents

- GENERAL INFORMATION 3**
- BASIC DESIGN 3**
- DERATING AND TOLERANCES..... 4**
- OPTIONS 5**
- VENTILATION 6**
- MOTOR CONNECTION..... 7**
- DATA AND DRAWINGS IP54 8**

General information

T-T ELECTRIC proposes a series of square frame ac motors for variable speed drives applications. This asynchronous motor has been developed and designed to achieve the same dynamic performance as for DC motors series.

The AC square motor complies with IEC600 34 standards and responds to the requirements for most industrial applications. Its flexible square frame design facilitates its integration into all types of machinery.

TYPE OF DESIGNATION

Frame Size	Core Length
71	A,B
80	A,B
90	A,B
100	A,B,C,D,E
132	A,B,C,D,

Example :

AMS 71 – 4 B

AMS : type of motor
 71 : frame size / centre height in mm
 4 : number of poles
 B : core length

OPERATING CURVES

The mechanical and technical characteristics of AMS motors can be compared to DC motors.

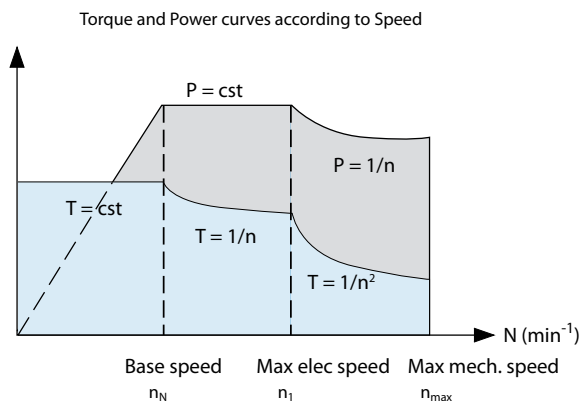

Basic design

Main features

- Winding coils insulation: class H according to CEI EN 60034-1
- Thermal dimensioning: class F according to CEI EN 60034-1
- Protection degree: IP54 according to CEI EN 60034-5
- Cooling: IC 416 according to CEI EN 60034-6
- Balancing degree: G 2,5 according to ISO 1940 (half-key balancing for key shafts according to CEI 2-23)
- Construction form: AMS71, AMS80, AMS90 B5 (IM 3001); AMS100, AMS132 IM B35 (IM 2001) according to CEI EN 60034-7
- Running position: any one
- Lubricated for life ball bearings
- Thermal protection: thermal cut-out with normally closed contact. Operating temperature 140°C. (Maximum voltage 250 Vac, maximum current 6 Aac with $\cos\phi = 1$)
- Power connection with six connection clamps on terminal board with thermal protection in terminal box
- Painting: epoxy-poliamide primer anticorrosive (RAL 7015)
- Reference conditions: environment +40°C, max.; height 1000m above sea level; relative air humidity less than 90% (without condensation)
- Storage temperature: -20°C ÷ +70°C

Standard encoder

Power supply: 4.5 - 32 V
 Output circuit: TTL or HTL
 Resolution: 1 ... 8192, 16384, 32768, 65536 ppr
 Channel: A, A-, B, B-, Z, Z-
 Maximum load current: 30 mA
 Maximum frequency: 820 kHz
 Operating speed: 9000 rpm
 Protection: IP65
 Working temperature: -30 ... +100 °C
 Permissible relative humidity: 90% (without condensation)
 M23 – 12 pins connector (with solder free part)

Derating and tolerances

Ambient temperature and altitude

Motors are designed to operate between -5°C to maximum 40°C ambient temperature and at a maximum altitude of 1000 m above sea level. If ambient temperature or altitude is higher the motor torque/power is derated according to the table below:

Altitude (m)	Temperature (°C)			
	30	40	50	60
1000	1	1	0.9	0.8
2000	1	0.93	0.85	0.75
3000	0.93	0.85	0.77	0.64
4000	0.85	0.73	0.65	0.5

Duty

Motor power output can be increased depending on duty types defined by IEC600 34-1. Correction factors are given in the table below:

Duty	Operating time		
	10'	30'	60'
S2	1.6	1.3	1.1
	Cyclic duration factor		
	25%	40%	60%
S3	1.4	1.2	1.1
S6	1.4	1.3	1.2

The maximum constant power speed n_1 will be reduced based on the type of duty and the required overload.

Overload capacity:

IEC standard 600 34-1: 160% FLT/FLC for 1 minute every 10 minutes.

Electrical and mechanical tolerances

	Efficiency by summation losses	Efficiency by input-output test	Power factor	Slip	Max torque	Inertia	Noise level
PN (kW) <150	-15% (1- η)	-15% (1- η)	-1/6 (1-cos ϕ)	+/-20%	-10%	\pm 10%	+3dB(A)
PN (kW) >150	-10% (1- η)	-15% (1- η)	-1/6 (1-cos ϕ)	+/-20%	-10%	\pm 10%	+3dB(A)

Tolerances are in accordance with IEC 600 34-1 and based on test procedure in accordance with IEC 600 34-2.

Options

- Sine/Cosine encoder 1 Vpp - 1024 ppr
- Absolute encoder single-turn or multi-turn
- Resolver 2 poles, 7Vrms, transformation ratio 0.5
- Holding brake
- Shaft without key
- Thermal protection with KTY84-130 or PTC
- Fan 3-phase 400V-50/60Hz for AMS100 and AMS132
- Roller bearings for AMS100 and AMS132
- Construction form: IM B3/B35/B14/B34 according to CEI EN 60034-7 for AMS71, AMS80, AMS90
- Terminal box on left or right side (except for AMS132)
- Oil seal (it is assembled only when the coupling is oil-bath lubricated)
- Motors with system electrical insulation certificate UL (File E316823) with extension to Canada
- Motors AMS100 A/B/C/D and AMS132 A/B/C/D with certifications UL (File 247151) with extension to Canada
- Special design on customer's specifications

Permissible Radial Loads

The calculation of the maximum radial rating refers to 20,000 working hours with ball bearing and load on the shaft projection centre. The axial load must not exceed 20% of the maximum radial rating.

Motor size	RADIAL LOAD (N)							
	500 rpm	1000 rpm	1500 rpm	2000 rpm	2500 rpm	3000 rpm	3500 rpm	4000 rpm
AMS 71	840	700	610	550	510	480	460	440
AMS 80	1290	1020	890	810	750	700	670	640
AMS 90	1750	1380	1200	1090	1010	950	900	860
AMS 100 ¹⁾	2950	2300	2000	1800	1700	1600	1500	1400
AMS 132	5600	4400	3800	3450	3200	3000	2800	2700

1) Radial load verify for motors AMS100L and AMS100P with shaft 38x80mm

Warning: avoid axial shocks on the shaft during the assembly.

Bearings

Standard bearing are shielded and pre-lubricated for life. Following table shows bearing types foreseen:

Motor type	AMS 71	AMS 80	AMS 90	AMS 100	AMS 132
Driving end bearing	6004 ZZ	6205 ZZ	6206 ZZ	6209 ZZ C3 NU 209 ECP C3 ¹⁾	6310 ZZ C3 NU 310 C3 ¹⁾
No-driving end bearing	6203 ZZ	6204 ZZ	6304 ZZ	6306 ZZ C3	6209 ZZ C3

1) Option available on request. For motors with these bearings, the maximum motor speed is reduced and need periodic lubrications.

Ventilation

AMS Motors are provided with axial electric fan mounted on the same axis as the motor.

Motor type	AMS 71 AMS 80A IP54	AMS 80 B,C AMS 90A IP54	AMS 90 B,C,D IP54	AMS 100 IP54	AMS 132 IP54	Unit
Three phase voltage supply	-	-	-	400Y (on request)	400Y/230Δ (on request)	Vac
Single phase supply voltage +6%-10%	230	230	230	230 (standard)	230 (standard)	Vac
Frequency	50/60	50/60	50/60	50/60 50/60 ¹⁾	50/60 50/60 ¹⁾	Hz
Current	0,1/0,08	0,1/0,09	0,11/0,13	0,36/0,44 0,13/-- ¹⁾²⁾ 0,11/-- ¹⁾³⁾	0,7/0,95 0,27/0,47 ¹⁾²⁾ 0,35/0,61 ¹⁾³⁾	Aac
Air flow minimum clearance	50	50	50	100	120	mm
Air flow	180	204	408	570	1450	m ³ /h
Pressure	80	72	182	320	600	Pa
Fan protection degree	54	54	54	44	44	IP

- 1) Value related to three phase fan available only on request
- 2) Current at 50Hz with connection Y/D
- 3) Current at 60Hz with connection Y/D

Holding brake

On request is possible mounting a holding brake on the motor rear cover. The brake is electromechanical with springs with braking action in case of loss of supplying. The brake need to be connected and disconnected when the rotor is not running.

Motor type	AMS 71	AMS 80	AMS 90	AMS 100	AMS 132 IP54 AMS 132 A,B,C	Unit
Static braking torque 1)	6	6	23	60	200	Nm
Voltage supply ± 5% 2)	24	24	24	24	24	Vdc
Input power	20	20	32	50	60	W
Max. speed of braking	3000	3000	3000	3000	3000	rpm
Max. energy at 1 insert./hour	3	3	10	35	50	kJ
Brake inertia	0,15	0,15	2	7	28	Kgcm ²
Additional weight	1,2	1,2	3,9	10	20	kg

- 1) Braking torque tolerance +/-20% (slight grinding necessary)
- 2) Different voltage available on request
- 3) For vertical mounting (V1, V3, etc.) please contact our technical office

Performance tables

The motor performance tables are referred to motor supply from inverter (3x400Vrms) and with star (Y) connection phases motor (if not different indications).

Motor connection

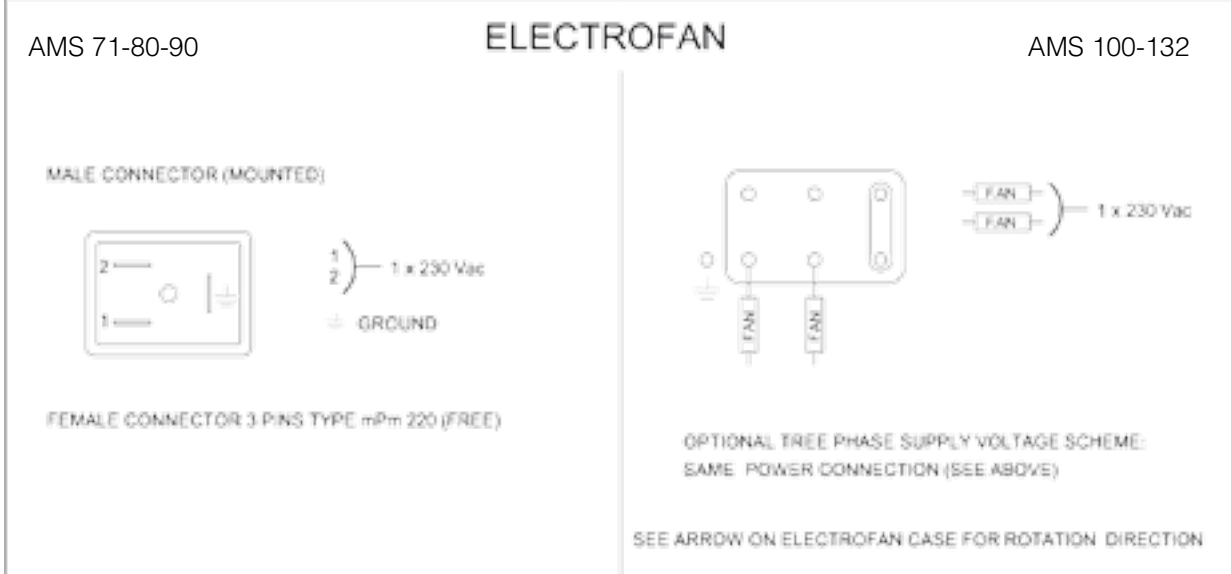
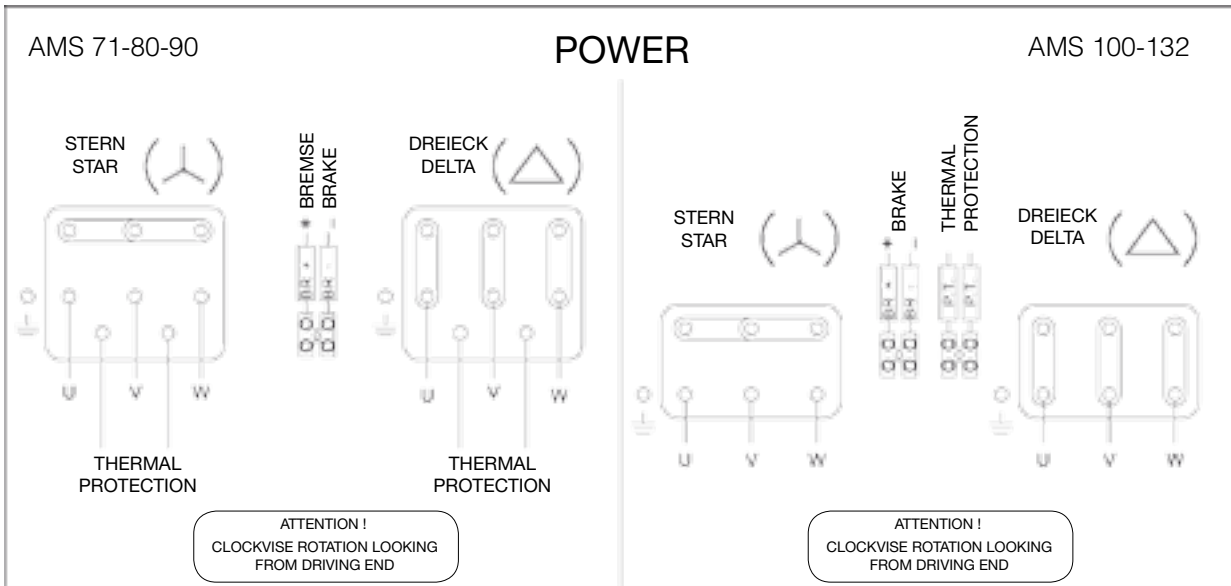

ENCODER SICK-VSF60

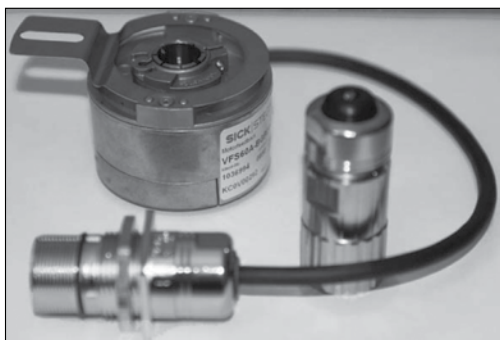

MALE CONNECTOR:
INTERCONTEC
AKUA020MS06620203.000
(MOUNTED)

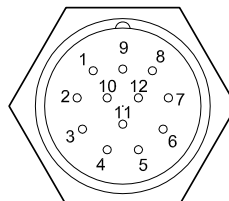

PLUG-IN FACE VIEW

FEMALE CONNECTOR:
SIZE M23 12 PINS (FREE)

INTERCONTEC
ASTA013FS100035000

PIN	SIGNAL TTL/HTL	EXPLANATION
1	B ₋	Signal line
2	N.C.	Not connected
3	Z	Signal line
4	Z ₋	Signal line
5	A	Signal line
6	A ₋	Signal line
7	N.C.	Not connected
8	B	Signal line
9	Shield	Housing potential
10	GND	Encoder supply voltage
11	N.C.	Not connected
12	U _s	Power supply ¹⁾

¹⁾Potential free to housing

	Nominal speed	Nominal power	Nominal torque	Nominal voltage	Nominal current	Maximum torque	Maximum speed at constant power	Maximum mechanical speed	Rotor inertia	Weight
Type	Nn rpm	Pn kW	Tn Nm	Vn V	In A	Tmax Nm	Np rpm	Nmax rpm	J kgm ²	Kg
AMS 71 A	1398	0,37	2,5	400	1,07	5	2800	7000	0,00076	8,5
	2508	0,64	2,5	400 ¹⁾	1,86 ¹⁾	5	5000			
	2907	0,76	2,5	400	2,45	5	5500			
AMS 71 B	1500	0,63	4	356	2,16	8	4500	7000	0,00087	10
	2670	1,09	4	356	3,75	8	7000			
	3000	1,1	4	380	2,85	8	5500			
AMS 80 A	1405	0,75	5	380	1,94	10	2500	7000	0,0017	11
	2515	1,30	5	380 ¹⁾	3,37 ¹⁾	10	4400			
	2910	1,5	5	380	4,33	10	5000			
AMS 80 B	1410	1,1	7,5	400	2,92	15	2600	7000	0,0024	13
	2520	1,91	7,5	400 ¹⁾	5,22 ¹⁾	15	4400			
	2910	2,2	7,5	400	5,84	15	5000			
AMS 90 A	1422	1,5	10	400	3,4	25	2500	7000	0,0024	15,5
	2530	2,6	10	400 ¹⁾	5,9 ¹⁾	25	4350			
	3000	3,15	10	400	7,1	25	6000			
AMS 90 B	1425	2,2	15	400	5	29	2500	7000	0,0033	20
	2487	3,9	15	400 ¹⁾	8,8 ¹⁾	29	4350			
	3000	4,74	15	400	10,3	29	5500			
AMS 90 C	1416	3	20	380	6,3	35	3500	7000	0,0043	24
	2505	5,2	20	400 ¹⁾	11 ¹⁾	35	4000			
	2898	6	20	400	13,2	35	5000			
AMS 90 D	1425	4	27	400	9	40	2700	7000	0,0057	30
	2535	7	27	400 ¹⁾	15,7 ¹⁾	40	4800			
	2820	8	27	400	19	40	5400			

1) Delta connection (D)

	Nominal speed	Nominal power	Nominal torque	Nominal voltage	Nominal current	Maximum torque	Maximum speed at constant power	Maximum mechanical speed	Rotor inertia	Weight
Type	Nn rpm	Pn kW	Tn Nm	Vn V	In A	Tmax Nm	Np rpm	Nmax rpm	J kgm ²	Kg
AMS 100 A	1000	2,6	24,8	380	6,8	50	2000	7000 ²⁾	0,009	38
	1424	4	26,8	380	8,98	53	2800			
	2020	5,3	25	380	12	50	4200			
	2540	6,5	24,6	380 ¹⁾	15,6 ¹⁾	49	5000			
	2938	7,5	24,5	380	17,4	49	5500			
AMS 100 B	607	2,6	40,9	380	7,0	80	1200	7000 ²⁾	0,013	45
	1015	4,3	40,5	380	9,7	90	2250			
	1498	6	38,2	380	13,0	95	3750			
	2013	7,8	37,0	380	16,4	100	5400			
	2520	9	34,1	380	18,9	90	6500			
	3000	10,2	32,5	380	22	85	7000			
AMS 100 C	604	3,1	49,0	380	7,9	105	1300	7000 ²⁾	0,016	55
	1022	5,2	48,6	380	12,1	115	2500			
	1508	7,2	45,6	380	16,4	120	4150			
	2018	9,1	43,1	380	20,6	120	5750			
	2524	10,5	39,7	380	21,6	105	6750			
	3003	11,8	37,5	380	24,5	100	7000			
AMS 100 D	603	3,8	60,2	380	10,3	135	1350	7000 ²⁾	0,02	59
	1014	6,2	58,4	380	14,6	130	2250			
	1513	8,5	53,6	380	19,7	160	4500			
	2026	10,8	50,9	380	24,6	160	6450			
	2504	12,2	46,5	380	26,5	140	7000			
	3010	13,3	42,2	380	27,1	120	7000			
AMS 100 E	609	4,6	72,1	380	11,8	175	1450	5400	0,025	72
	1020	7,3	68,3	380	17,6	195	2900			
	1519	10	62,9	380	23	200	4850			
	2000	12,5	59,7	380	28,5	200	6650			
	2502	14	53,4	380	29,1	160	7000			
	3010	15,5	49,2	380	31,5	140	7000			

1) Delta motor connection (D)
 2) 6700 rpm with roller bearings

	Nominal speed	Nominal power	Nominal torque	Nominal voltage	Nominal current	Maximum torque	Maximum speed at constant power	Maximum mechanical speed	Rotor inertia	Weight
Type	Nn	Pn	Tn	Vn	In	Tmax	Np	Nmax	J	Kg
	rpm	kW	Nm	V	A	Nm	rpm	rpm	kgm ²	
AMS 132 A	1066	8	71,7	380	18,1	190	2800	6400 ¹⁾	0,052	91
	1581	12	72,5	380	25,7	195	4200			
	2104	17	77,2	380	36,4	220	6000			
	2654	20	72,0	380	42,2	210	6400			
	3167	24	72,4	380	50,7	220	6400			
AMS 132 B	1059	12	108	380	26,3	290	2800	6400 ¹⁾	0,073	115
	1581	17	103	380	35,2	250	3900			
	2101	22	100	380	42,2	300	6400			
	2652	28	101	380	57,8	300	6400			
	3150	33	100	380	67,9	300	6400			
AMS 132 C	1062	17	153	380	36,4	410	2800	6400 ¹⁾	0,099	146
	1581	24	145	380	49,2	370	4100			
	2101	32	145	380	65,2	390	5600			
	2651	38	137	380	80,4	480	6400			
	3152	44	133	380	90,2	420	6400			
AMS 132 D	1060	20	180	380	45,5	500	2800	5400 ¹⁾	0,122	174
	1584	28	169	380	57,3	450	4200			
	2102	37	168	380	74,6	450	5400			
	2653	44	158	380	88,7	460	5400			
	3153	50	151	380	99,7	430	5400			

1) 5000 rpm with roller bearings

B5

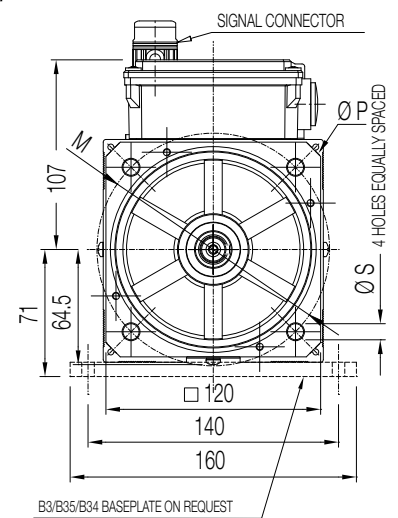
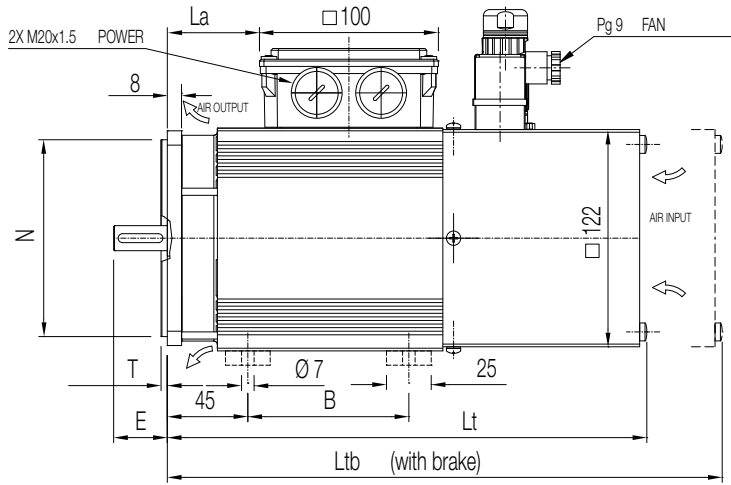

B14

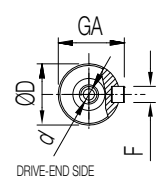
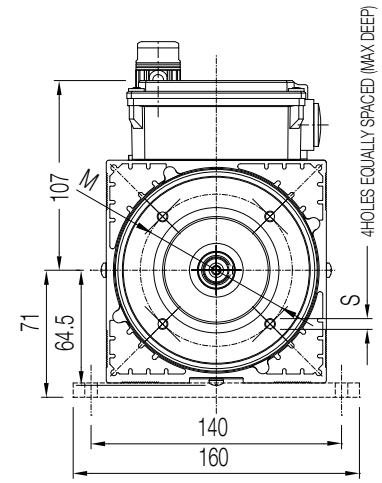
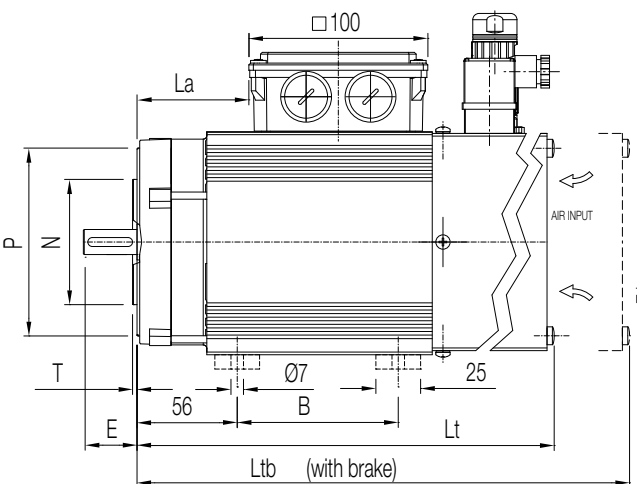

Type	Length				Shaft						Front flange										
	B	La	Lt	Ltb	D (1)	D (2)	E (1)	E (2)	GA (1)	GA (2)	F (1)	F (2)	d (1)	d (2)	P	N	T	M	S		
AMS 71	A	B5	90	51,5	270	312	14j6	19j6	30	40	16	21,5	5	6	M5	M6	160	110 j6	3,5	130	9
	B		90	62,5	281	323	14j6	19j6	30	40	16	21,5	5	6	M5	M6	105	70 j6	2,5	85	M6

(1) Standard (2) Option

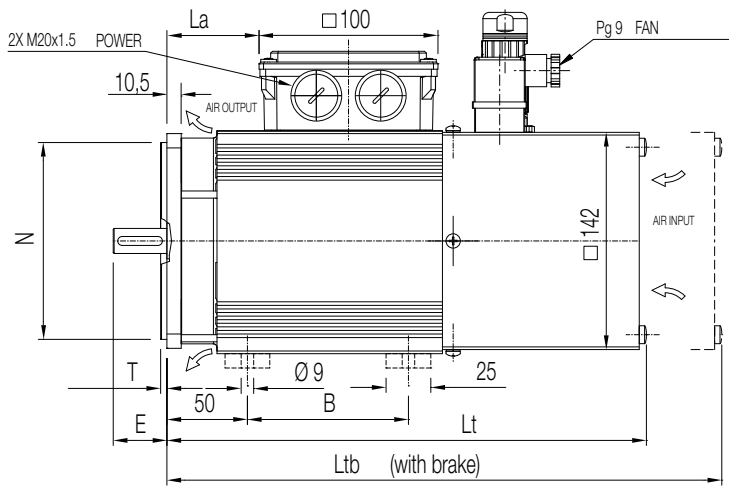

B5

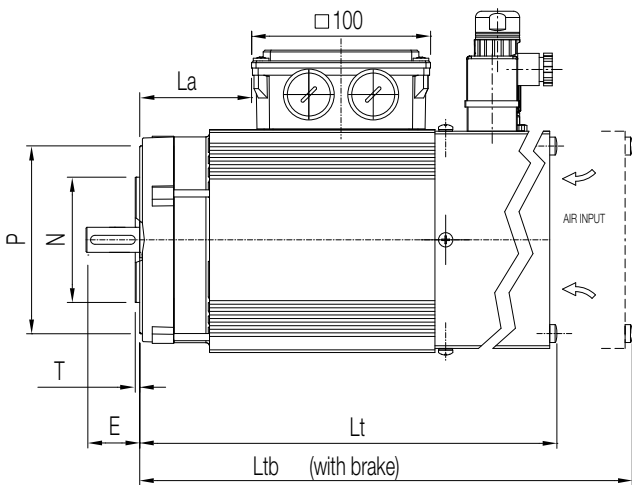
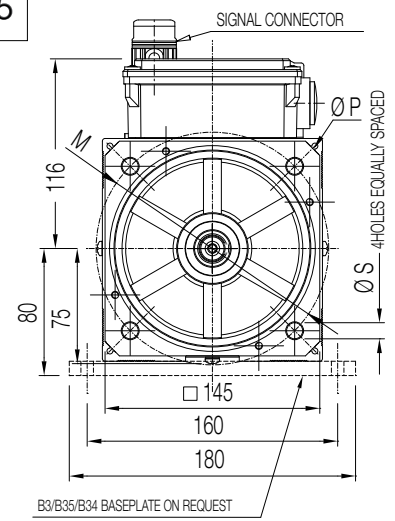

B14

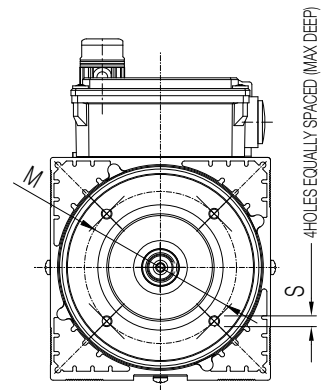
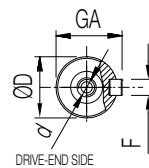

Type		Length				Shaft								Front flange							
		B	La	Lt	Ltb	D (1) (2)	E (1) (2)	GA (1) (2)	F (1) (2)	d (1) (2)	P	N	T	M	S						
AMS 80	A	B5	100	78	285	325	19j6	24j6	40	50	21,5	27	6	8	M6	M8	200	130 j6	3,5	165	11
	B																				
	A	B14	-	78	285	325	19j6	24j6	40	50	21,5	27	6	8	M6	M8	120	80 j6	2,5	100	M6
	B																				

(1) Standard (2) Option

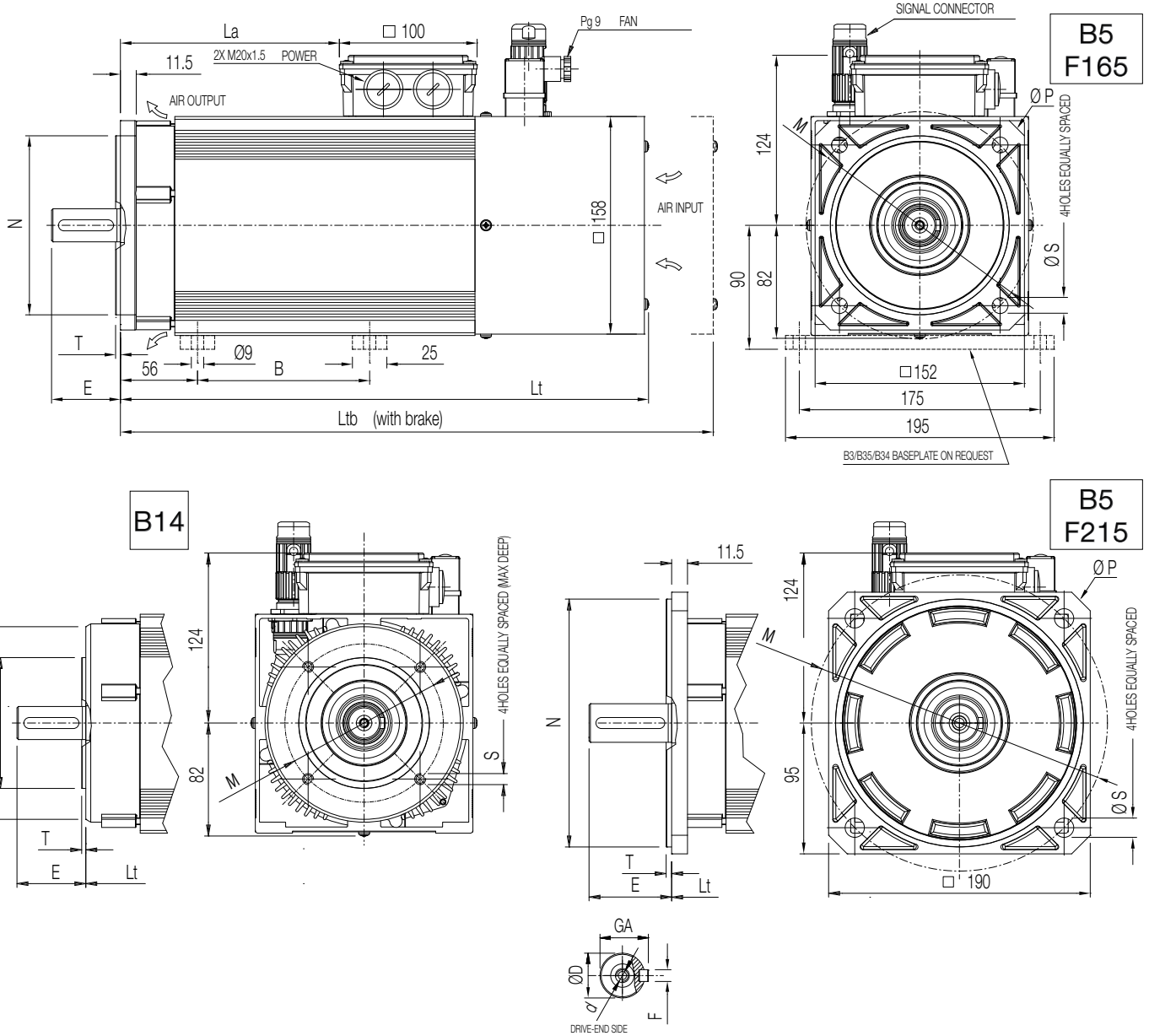

Type		Length				Shaft					Front flange					
		B	La	Lt	Ltb	D	E	GA	F	d	P	N	T	M	S	
AMS 90	A	B5 / F165 (standard)	100	84	294	344	24	50	27	8	M8	200	130 j6	3,5	165	11,5
	B		125	119	345	395										
	C		125	159	385	435										
	D		185	229	455	505										
AMS 90	A	B5 / F215 (option)	100	84	294	344	28	60	31	8	M10	250	180 j6	4	215	13,5
	B		125	119	345	395										
	C		125	159	385	435										
	D		185	229	455	505										
AMS 90	A	B14	-	84	294	344	24	50	27	8	M8	140	95 j6	3	115	M8
	B		-	119	345	395										
	C		-	159	385	435										
	D		-	229	455	505										

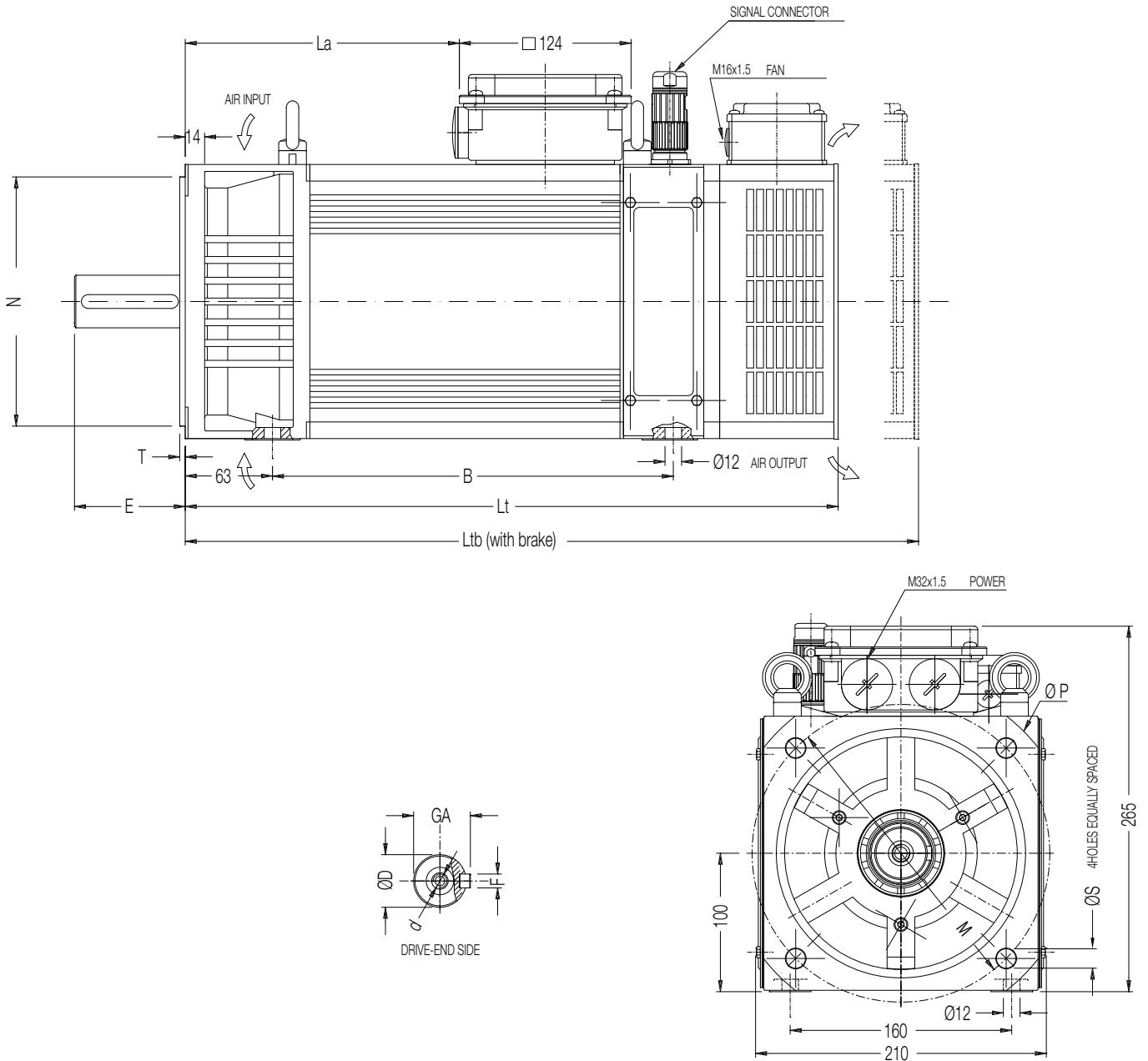

Type	Lenght				Shaft								Front flange						
	B	La	Lt	Ltb	D		E		GA		F		d		P	N	T	M	S
					(1)	(2)	(1)	(2)	(1)	(2)	(1)	(2)	(1)	(2)					
AMS 100	A	240	148	422															
	S	290	198	472															
	M	320	228	502	28j6	38K6	60	80	31	41	8	10	M10	M12	250	180 j6	4	215	14
	L	365	273	547															
	P	420	328	602															

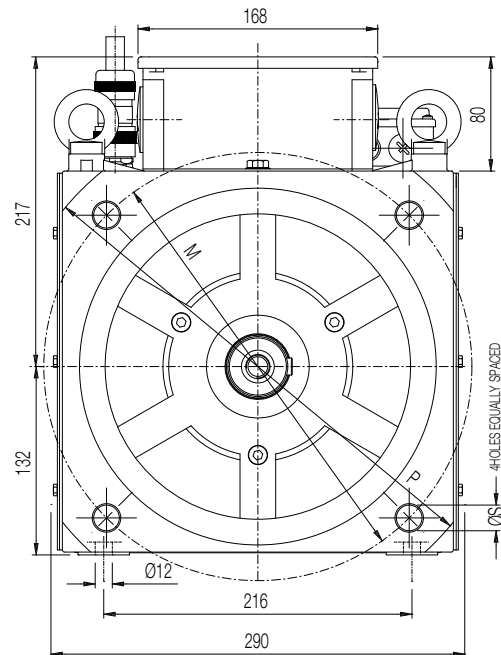
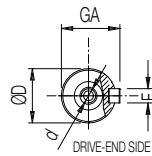
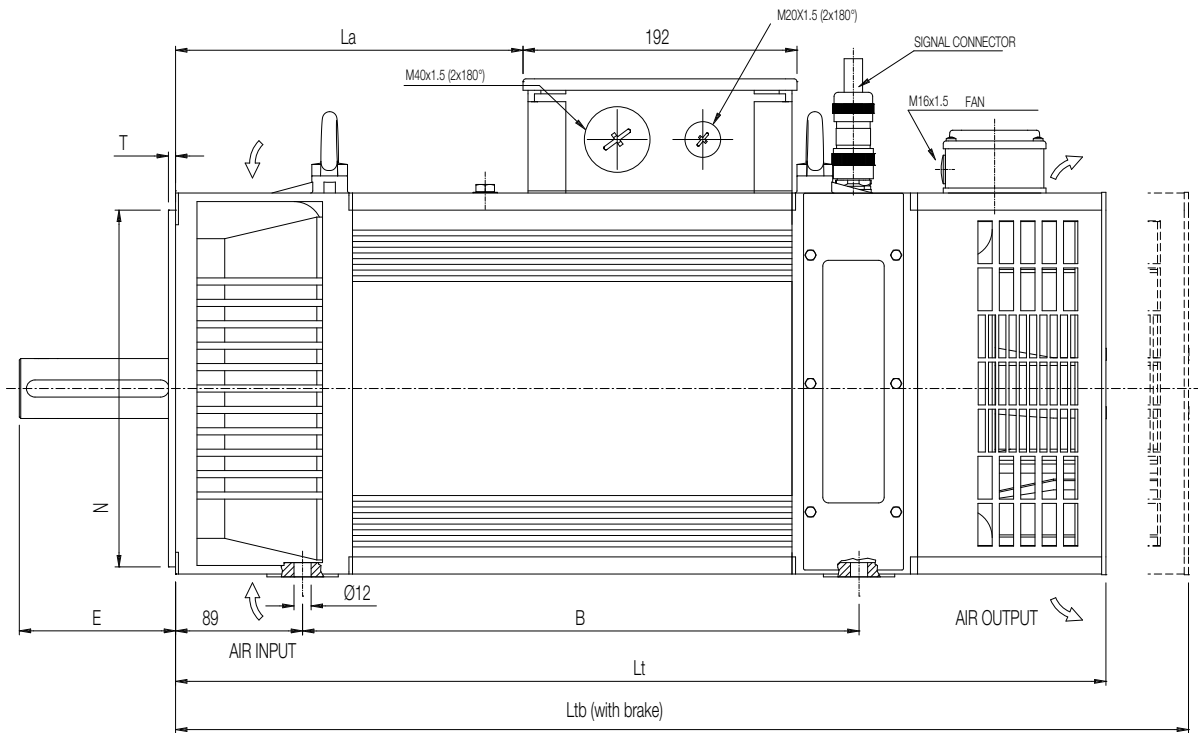

Type	Length				
	B	La	Lt	Ltb	
AMS 132	S	320	173	585	705
	M	390	243	655	775
	L	480	333	745	865
	P	560	413	825	945

Type	Shaft					Front flange					
	D	E	GA	F	d	P	N	T	M	S	
AMS 132	B35	38 k6	80	41	10	M12	300	230 j6	4	265	14
		42 k6	110	45	12	M16	350	250 j6	5	300	18
		48 k6	110	51,5	14	M16	350	250 j6	5	300	18

Founded over 100 years ago, T-T Electric is a world-class supplier of top-quality industrial electric motors and drives. Pioneers in the industry, we are an experienced and established manufacturer of a comprehensive and cost-effective range of highly reliable drive products. They are used around the world in the toughest of application environments and in all industrial segments.

Driven by customer demand, T-T Electric is continually researching product excellence and manufacturing

process perfection. The flexible product design ensures easy adaptations to customer requirements. This, combined with unequalled short delivery times, make T-T Electric a reference within industry. Our extensive support services include diagnostics and maintenance on site as well as full overhaul in our own repair facilities.

T-T Electric is committed to a working partnership with our customers. For mutual benefit, we focus on complete and innovative solutions together.



France

22 rue du 8 mai 1945
F-95340 PERSAN

Tel: +33 (0) 1 30 28 62 01
Fax: +33 (0) 1 34 70 21 79
E-mail: info@t-telectric.fr



UK

T-T Electric
Unit 7A Waterloo Park
Upper Brook Street
STOCKPORT SK1 3BP
Tel: +44 (0) 161 480 0037
Fax: +44 (0) 161 476 4390
E-mail: john.legg@t-telectric.com

Germany

T-T Electric
Theodor-Stern-Kai 1
60596 Frankfurt
Tel : +49 (0)69 96765 2332
Fax :+49 (0)69 96765 2333
E-mail: info@t-telectric.com

Russian Federation

VIK-Industry
B. Nizhegorodskaya
600016 Vladimir
Tel : +7 (4922) 47 55 74
Fax : +7 (4922) 47 55 74
E-mail: info@vecgroup.com

USA

T-T Electric USA
PO Box 180074
Delafield, WI 53018
Phone # 262-244-0581
Fax # 888-761-1060
E-mail: info@ttelectricusa.com

Sweden

Thrige Electric / Regal
Lefflersgatan 1
S-75450 Uppsala
Tel: +46 (0) 18 657000
Fax: +46 (0) 18 107478
E-mail: info@regal.se

China

T-T Electric
RM 24-04 Jiafu Int'l Mansion
515 Ganjiang West Rd
SUZHOU P.R. CHINA
Tel: (+86512) 693 25210
Fax: (+86512) 693 25213
E-mail: jacson@metals-star.com